

Vol. 14 No. 1 January - February 2019

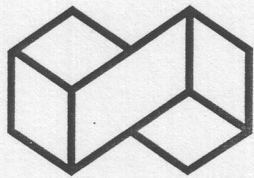

Journal of  
**Thai Interdisciplinary Research**

ISSN 2465-3837

# Journal of Thai Interdisciplinary Research

## Editorial Board of Journal of Thai Interdisciplinary Research

|                           |                                 |
|---------------------------|---------------------------------|
| Yongyudh Vajaradul        | (Editor)                        |
| Pranom Othaganont         | (Deputy Editor)                 |
| Sommay Peathanom          | (Deputy Editor)                 |
| Prabhas Chongstitvatana   | (Editorial Board)               |
| Orawon Chailapakul        | (Editorial Board)               |
| Tuantan Kitpaisalsakul    | (Editorial Board)               |
| Kanchana Boonsong         | (Editorial Board)               |
| Sayam Aroonsrimorakot     | (Editorial Board)               |
| Wilairat Kirin            | (Editorial Board)               |
| Soraj Kaiboriboon         | (Editorial Board)               |
| Wanida Treesawat          | (Editorial Board)               |
| Surapong Charasrosjanakul | (Editorial Board)               |
| Sumnieng Ongsupankul      | (Editorial Board)               |
| Porn-tip Andhivarothai    | (Editorial Board)               |
| Orapun Metadilokul        | (Editorial Board)               |
| Prasutr Thavornchaisit    | (Editorial Board)               |
| Artcha Boongrapu          | (Editorial Board)               |
| Phatcharasak Arlai        | (Editorial Board and Secretary) |
| Santi Koonkarnkhai        | (Manager)                       |

## International Editorial Board of Journal of Thai Interdisciplinary Research

|                   |                      |                   |
|-------------------|----------------------|-------------------|
| (Editor)          | Muhammad Yunus       | (Editorial Board) |
| (Deputy Editor)   | Manfred Koch         | (Editorial Board) |
| (Deputy Editor)   | Jun Yu               | (Editorial Board) |
| (Editorial Board) | Tou Teck Yong        | (Editorial Board) |
| (Editorial Board) | Lance Chun Che Fung  | (Editorial Board) |
| (Editorial Board) | Warren Y. Brockelman | (Editorial Board) |
| (Editorial Board) | Manfred Hartard      | (Editorial Board) |

## Administrative Committees of Journal

|                    |                           |
|--------------------|---------------------------|
| Virat Pingkeaw     | (President)               |
| Sommay Peathanom   | (Vice President)          |
| Yongyudh Vajaradul | (Committee)               |
| Pranom Othaganon   | (Committee)               |
| Phatcharasak Arlai | (Committee and Secretary) |

## Management and Distribution Section

|                  |
|------------------|
| Ladda Khemnark   |
| Paphada Srisuwan |

**Publisher:** Research and Development Institute, Nakhon Pathom Rajabhat University, 85 Malaiman road, Amphur Muang, Nakhon Pathom 73000, Thailand

**Origin:** The Journal of Thai Interdisciplinary Research was established with the cooperation of seven institutes:

- Nakhon Pathom Rajabhat University
- The Royal Society of Thailand Committee of Interdisciplinary Research and Development
- Interdisciplinary Research Foundation
- Phetchaburi Rajabhat University
- Muban Chombueng Rajabhat University
- Kanchanaburi Rajabhat University
- Rajamangala University of Technology Rattanakosin

## Objectives of Journal

1. To encourage and publish knowledge and useful opinions in any field of study
2. To support academicians and teachers in creating work beneficial to the academic community
3. To stimulate and support education at the university level

## Policies of the journal:

The Journal of Thai Interdisciplinary research publishes six issues per year. All submitted articles are subject to peer review, and must be approved by two experts in the relevant field prior to acceptance. Prior to review, all articles must pass a screening process which evaluates the articles' appropriateness for the journal, originality, proper formatting, and English proficiency. All material in each article that is not original must be properly referenced to the published literature. The editors reserve the right to modify articles in the interests of clarity and proper English usage. The opinions and views expressed in the journal are those of the authors of the respective articles and not those of the editors or publisher.

## Submission of articles:

Articles should be submitted on-line at <https://www.tci-thaijo.org/index.php/jtir>. The website contains full instructions about how to prepare and submit articles. Please contact the journal or editors for information at [jtir.npru@gmail.com](mailto:jtir.npru@gmail.com), or by phone at +66 3426 1053, or +66 3410 9300 ext. 3909.



QR Code

## Editorial Note

The Journal of Thai Interdisciplinary Research (JTIR) was established with academic cooperation by the Nakhon Pathom Rajabhat University, The Royal Society of Thailand Committee of Interdisciplinary Research and Development, and Rajabhat University (Western Group). This Issue, Volume 14 No. 1 (January–February 2019) contains ten research articles in diverse fields: (1) Causes of unusual pomelo leaf after flooding in Nakhon Pathom province, (2) Fruit morphological characteristics and fruit quality of pomelo cv. Taptim Siam grown in Nakhon Pathom and Nakhon Si Thammarat Provinces, (3) Genetic variations for ‘Nam Hom’ coconut (*Cocos nucifera* L.) grown in the western region of Thailand using AFLP markers, (4) Half binary exponential increment double decrement back-off algorithm to enhance the saturated throughput of IEEE802.11 wireless LAN, (5) The prototype development of traceability system of LSB steganography in image files with Base64 and MD5 encoding, (6) Analysis of salicylic acid using square-wave voltammetry with pre-concentration by solid phase extraction onto magnetite nanoparticles, (7) Cloud storage application functionalities from users’ perspectives, (8) Effects of chelation therapy in patients affected from heavy metal toxicity from gold mining in Loei Province: case study of arsenic toxicity, (9) Applied social media and the effects of its use during vacation travel: A case study of Millennials in Thailand, and (10) Factors affecting performance of standard application and indicator for greenhouse gas emission in green office, Thailand.

The Editorial Board of the JTIR encourages anyone to submit articles for evaluation and review. The processes of submission, review and publication of articles are described on the journal’s website, <https://www.tci-thaijo.org/index.php/jtir>. The Editorial Board and Committees of the JTIR sincerely thank all peer reviewers who have sacrificed their time to help us produce a better journal, and also wish to thank all teachers, researchers and other academicians for submitting their valuable research to this journal. Finally, we thank readers of our journal who help to spread the knowledge and benefits gained to others. With your feedback and suggestions, we will strive to improve the quality and relevance of the JTIR.

Yongyudh Vajaradul  
Editor  
Journal of Thai Interdisciplinary Research

## Contents

Volume 14, No. 1, January – February 2019

|  | Page |
|--|------|
| <b>Research articles</b>   |      |
| <b>Causes of unusual pomelo leaf after flooding in Nakhon Pathom province</b><br>Kanya Sornsanit, Pornpan Usuwan, and Pongnart Nartvaranant  | 1    |
| <b>Fruit morphological characteristics and fruit quality of pomelo cv. Tabtim Siam grown in Nakhon Pathom and Nakhon Si Thammarat Provinces</b><br>Saowanee Kongsri and Pongnart Nartvaranant  | 5    |
| <b>Analysis of the genetic variations for 'Nam Hom' coconut (<i>Cocos nucifera</i> L.) grown in the western region of Thailand using AFLP markers</b><br>Pongnart Nartvaranant   | 12   |
| <b>Half binary exponential increment double decrement back-off algorithm to enhance the saturated throughput of IEEE802.11 wireless LAN</b><br>Jesada Sarthong   | 21   |
| <b>The prototype development of traceability system of LSB steganography in image files with Base64 and MD5 encoding</b><br>Paisan Simalaotao  | 29   |
| <b>Analysis of salicylic acid using square-wave voltammetry with pre-concentration by solid phase extraction onto magnetite nanoparticles</b><br>Phetlada Sanchayanukun, Prapanee Pengmarerng, and Sasithorn Muncharoen  | 35   |
| <b>Cloud storage application functionalities from users' perspectives</b><br>Thanyatida Gunadham   | 42   |
| <b>Effects of chelation therapy in patients affected from heavy metal toxicity from gold mining in Loei Province: case study of arsenic toxicity</b><br>Sirichada Plengphanich, Tewan Thaneerat, Pranee Limworawan, Ong-ard Sirikulphisut, and Noppapadol Tiensawang | 48   |
| <b>Applied social media and the effects of its use during vacation travel: A case study of Millennials in Thailand</b><br>Chalida Techajirakul and Kriengsin Prasongsukarn   | 53   |
| <b>Factors affecting performance of standard application and indicator for greenhouse gas emission in green office, Thailand</b><br>Sayam Aroonsrimorakot, Setrawut Phuynongpho, and Supapan Athirot   | 60   |



## Half binary exponential increment double decrement back-off algorithm to enhance the saturated throughput of IEEE802.11 wireless LAN

Jesada Sartthong

Department of Electrical Engineering, Faculty of Science and Technology, Nakhon Pathom Rajabhat University, Nakhon Pathom 73000, Thailand

### Abstract

In wireless local area network (WLAN), the back-off algorithm is used to reduce the collided packets in carrier sense multiple accesses with collision avoidance protocol (CSMA/CA). Normally, the collided packets occur when two or more packets are sent in the same timeslot. This research proposes a new back-off algorithm in retransmission process for improving the saturated throughput of IEEE802.11 WLAN. A proposed scheme is called half binary exponential increment double decrement (HBEIDD) back-off algorithm. The throughput performance of a proposed algorithm is compared with four existing back-off techniques namely: double increment double decrement (DIDD), exponential increment exponential decrement (EIED), binary exponential increment half decrement (BEIHD), and random increment binary exponential decrement (RIBED) back-off algorithms. The accuracy of all back-off algorithms is compared in a discrete time Markov chain model in fixed back-off states and contention window (CW) sizes. Numerical results show that the saturation throughput of HBEIDD back-off algorithm is more stable than the existing back-off techniques under high traffic load condition.

**Keywords:** back-off algorithm, CSMA/CA protocol, contention window, saturation throughput

**Article history:** Received 18 May 2018, Accepted 28 February 2019

### 1. Introduction

Presently, a main practical problem of random multiple accesses in wireless channels is the collision of transmitted packets because the collision can degrade the throughput and fairness efficiency of WLAN. Back-off algorithm is a common technique for reducing the collision probability. One of the simplest ways to reduce the collision problem is the usage of a sampling random-time to delay the next retransmission packet. Significantly, a key concept of designing back-off algorithms is how to select an optimum contention window size for the maximum throughput, fairness index and smallest packet delay. In retransmission process, the next contention window size will be selected to be higher than the current size after a failed transmitted packet. A bottleneck problem is when the contention window is selected at a larger size, then the packet delay will also be higher. Many researches in this field aim to solve this problem. Several researches to address this issue have been reported in the literature.

Since 2000, Bianchi [1] introduced a discrete time Markov chain model in saturation channel to analyze the performance of IEEE 802.11 distributed coordination function WLAN as well-known Bianchi's model. The advantage of Bianchi's model is low

complexity, but its advantage is more accuracy at high traffic load condition. In fact, the back-off scheme which is presented in [1] and [2] is the binary exponential (BEB) back-off algorithm. The performance of BEB back-off algorithm is analyzed and presented that the optimum contention window size is  $n\sqrt{2T_c}$ , where  $n$  is the number of contending nodes, and  $T_c$  is the duration of a collision. Next, Chatzimisios and et al. [4, 5] introduced the double increment double decrement back-off algorithm (DIDD). The contention window size of the DIDD back-off algorithm is a double increment after a collided packet, and the CW is a double decrement after a successful packet transmission. Performance of DIDD back-off scheme can be enhanced in terms of throughput efficiency without estimating the number of contending nodes. Also, Nah-Oak Song and et al. [6] have proposed an exponential increment exponential decrease (EIED) back-off algorithm. The main characteristic of EIED back-off algorithm is that the contention window size is the exponential increment after a collided packet and the exponential decrement after a successful transmission. The throughput efficiency of EIED back-off method is presented that it is higher than the BEB back-off

\* Corresponding author; e-mail: sartthong@webmail.npru.ac.th

scheme. In addition, the authors [7]-[12] have presented the binary exponential increment half decrease back-off (BEIHD), random increment binary exponential decrease back-off (RIBED), and log back-off (LB) algorithms.

The aim of this research is to extend from the previous works, and develops the contention window size adjustment scheme to enhance the saturated throughput. A proposed technique will employ in the half binary exponential increment after a failure transmission and double decrement after a success transmission. The accuracy of the proposed scheme is compared in a discrete time Markov chain model. We consider the case of fixed back-off states and contention window sizes. The back-off states are varied from 0 to 7 states, and the contention window sizes are varied from 0 to 1023 timeslots.

In this research, the wireless channel is ideal and memory less condition. Many parameters are not investigated, such as hidden stations, captured effect, noises, and attenuation. All data packets are the same size, and medium access control uses the carrier sense multiple accesses with collision avoidance protocol. A current collision is independent in the past, and all contending nodes in a same service area are synchronized and saturated condition.

### 2. Existing Back-Off Algorithms

Four existing back-off algorithms have analyzed in this paper. Firstly, the double increment double decrement (DIDD) back-off algorithm can be modeled in a discrete time Markov chain as shown in Figure 1. Significantly, the contention window size of DIDD back-off technique is double increment after a failed transmission and a double decrement into the previous back-off state after a successful transmission. Using discrete Markov process, the probability of next state depends on the probability of current state.

In this investigation, parameter D means the frozen back-off countdown probability when the channel is sensed busy, and parameter C means the collision probability. Also, parameter j means the number of retransmissions or back-off states, and parameter cw means the contention window size (time-slot) in back-off process. Parameter  $A_{cw}^j$  is the probability of a contending node at back-off state j and contention window size cw. After a contending node has failed the first transmission, next retransmission process changes into back-off countdown process. Before the retransmitted packets are sent through wireless LAN channel, the size of contention windows is randomly selected and reduced slot-by-slot from cw to zero. In Figure 1, an initial back-off state is set to be the

minimum contention window size ( $A_{cw=7}^{j=0}$ ). We use the global balance equation in the queuing theorem to derive all state probabilities. The probability of  $A_{cw=7}^{j=0}$  is given by [1]

$$\begin{aligned} (1-C)A_{cw=0}^{j=0} + DA_{cw=7}^{j=0} + (1-C)A_{cw=0}^{j=1} &= (1-D)A_{cw=7}^{j=0} \\ (1-C)A_{cw=0}^{j=0} + (1-C)A_{cw=0}^{j=1} &= (1-2D)A_{cw=7}^{j=0} \\ A_{cw=7}^{j=0} &= \frac{(1-C)}{(1-2D)}A_{cw=0}^{j=0} + \frac{(1-C)}{(1-2D)}A_{cw=0}^{j=1} \end{aligned} \quad (1)$$

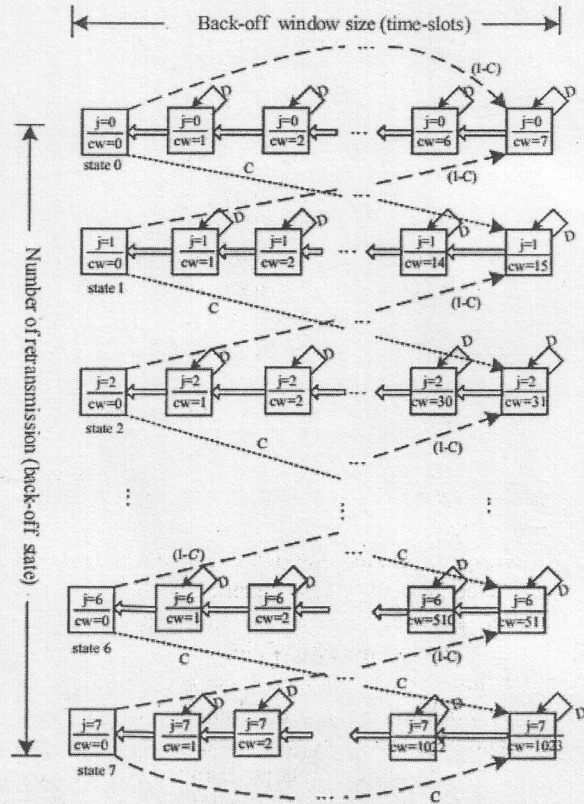

Figure 1 DIDD back-off algorithm

If wireless channel is still idle, the contention window sizes are reduced by one time-slot. Then the state probability moves to  $A_{cw=6}^{j=0}$  and it is derived by

$$\begin{aligned} (1-D)A_{cw=7}^{j=0} + DA_{cw=6}^{j=0} &= (1-D)A_{cw=6}^{j=0} \\ (1-D)A_{cw=7}^{j=0} &= (1-2D)A_{cw=6}^{j=0} \\ A_{cw=6}^{j=0} &= \frac{(1-D)}{(1-2D)}A_{cw=7}^{j=0} \end{aligned} \quad (2)$$

Substituting (1) into (2), we get

$$A_{cw=6}^{j=0} = \frac{(1-D)(1-C)}{(1-2D)^2} A_{cw=0}^{j=0} + \frac{(1-D)(1-C)}{(1-2D)^2} A_{cw=0}^{j=1} \quad (3)$$

If the channel is still idle for more than DIFS time, the contention window size continues to reduce slot-by-slot until to zero (cw=0). In a similar way (1) to (3), the probability of state  $A_{cw=0}^{j=0}$  can be derived as

$$A_{cw=0}^{j=0} = (1-C) \left[ \frac{(1-D)}{(1-2D)} \right]^7 A_{cw=0}^{j=0} + (1-C) \left[ \frac{(1-D)}{(1-2D)} \right]^7 A_{cw=0}^{j=1} \quad (4)$$

To simplify the notation, we denote  $H = (1-D)/(1-2D)$ . The maximum number of retransmission or back-off state is fixed at 8 states. Be applying a queuing theorem, the state probabilities of  $A_{cw=0}^{j=1}, A_{cw=0}^{j=2}, A_{cw=0}^{j=3}, A_{cw=0}^{j=4}, A_{cw=0}^{j=5}, A_{cw=0}^{j=6}$ , and  $A_{cw=0}^{j=7}$  can be derived by

$$A_{cw=0}^{j=1} = CH^{15} A_{cw=0}^{j=0} + (1-C)H^{15} A_{cw=0}^{j=2} \quad (5)$$

$$A_{cw=0}^{j=2} = CH^{31} A_{cw=0}^{j=1} + (1-C)H^{31} A_{cw=0}^{j=3} \quad (6)$$

$$A_{cw=0}^{j=3} = CH^{63} A_{cw=0}^{j=2} + (1-C)H^{63} A_{cw=0}^{j=4} \quad (7)$$

$$A_{cw=0}^{j=4} = CH^{127} A_{cw=0}^{j=3} + (1-C)H^{127} A_{cw=0}^{j=5} \quad (8)$$

$$A_{cw=0}^{j=5} = CH^{255} A_{cw=0}^{j=4} + (1-C)H^{255} A_{cw=0}^{j=6} \quad (9)$$

$$A_{cw=0}^{j=6} = CH^{511} A_{cw=0}^{j=5} + (1-C)H^{511} A_{cw=0}^{j=7} \quad (10)$$

$$A_{cw=0}^{j=7} = CH^{1023} A_{cw=0}^{j=6} + CH^{1023} A_{cw=0}^{j=7} \quad (11)$$

Secondly, Figure 2 shows the exponential increment exponential decrement (EIED) back-off algorithm which is modeled in a discrete time Markov chain. The EIED back-off algorithm is different from the DIDD back-off algorithm, if a retransmitted packet is unsuccessful then a new contention window size is selected an exponential increment. On the contrary, the packet is successful transmission; a new contention window size will be an exponential decrement. Similarly in (1) to (4), the state probabilities of  $A_{cw=0}^{j=0}, A_{cw=0}^{j=1}, A_{cw=0}^{j=2}, A_{cw=0}^{j=3}, A_{cw=0}^{j=4}, A_{cw=0}^{j=5}, A_{cw=0}^{j=6}, A_{cw=0}^{j=7}$  can be derived as

$$A_{cw=0}^{j=0} = \frac{[(1-C/15)/7]}{[(1-C/15)/7 + C/15]} \sum_{Z=1}^7 H^Z A_{cw=0}^{j=0} + \frac{[(1-C/31)/7]}{[(1-C/15)/7 + C/15]} \sum_{Z=1}^7 H^Z A_{cw=0}^{j=1} \quad (12)$$

$$A_{cw=0}^{j=1} = \frac{C}{15[(1-C/31)/7 + C/31]} \sum_{Z=1}^{15} H^Z A_{cw=0}^{j=0} + \frac{[(1-C/63)/15]}{[(1-C/31)/7 + C/31]} \sum_{Z=1}^{15} H^Z A_{cw=0}^{j=2} \quad (13)$$

$$A_{cw=0}^{j=2} = \frac{C}{31[(1-C/63)/15 + C/63]} \sum_{Z=1}^{31} H^Z A_{cw=0}^{j=1} + \frac{[(1-C/127)/31]}{[(1-C/63)/15 + C/63]} \sum_{Z=1}^{31} H^Z A_{cw=0}^{j=3} \quad (14)$$

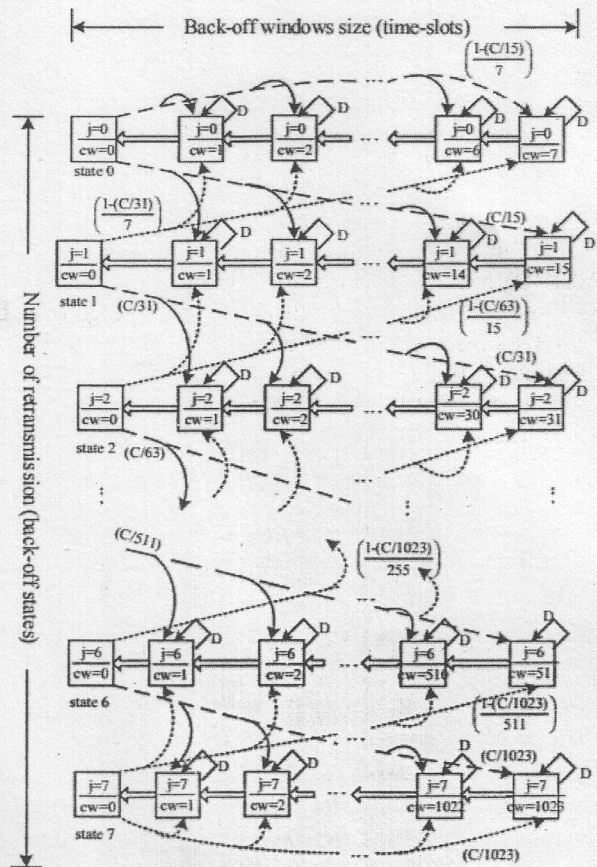

Figure 2 EIED back-off algorithm

$$A_{cw=0}^{j=3} = \frac{C}{63[(1-C/127)/31 + C/127]} \sum_{Z=1}^{63} H^Z A_{cw=0}^{j=2} + \frac{[(1-C/255)/63]}{[(1-C/127)/31 + C/127]} \sum_{Z=1}^{63} H^Z A_{cw=0}^{j=4} \quad (15)$$

$$A_{cw=0}^{j=4} = \frac{C}{127[(1-C/255)/63+C/255]} \sum_{Z=1}^{127} H^Z A_{cw=0}^{j=3} + \frac{[(1-C/511)/127]}{[(1-C/255)/63+C/255]} \sum_{Z=1}^{127} H^Z A_{cw=0}^{j=5} \quad (16)$$

$$A_{cw=0}^{j=5} = \frac{C}{255[(1-C/511)/127+C/511]} \sum_{Z=1}^{255} H^Z A_{cw=0}^{j=4} + \frac{[(1-C/1023)/255]}{[(1-C/511)/127+C/511]} \sum_{Z=1}^{255} H^Z A_{cw=0}^{j=6} \quad (17)$$

$$A_{cw=0}^{j=6} = \frac{C}{511[(1-C/1023)/255+C/1023]} \sum_{Z=1}^{511} H^Z A_{cw=0}^{j=5} + \frac{[(1-C/1023)/511]}{[(1-C/1023)/255+C/1023]} \sum_{Z=1}^{511} H^Z A_{cw=0}^{j=7} \quad (18)$$

$$A_{cw=0}^{j=7} = \frac{C}{1023[(1-C/1023)/511+C/1023]} \sum_{Z=1}^{1023} H^Z A_{cw=0}^{j=6} + \frac{[(1-C/1023)/511]}{1023[(1-C/1023)/511+C/1023]} \sum_{Z=1}^{255} H^Z A_{cw=0}^{j=7} \quad (19)$$

Thirdly, Figure 3 shows a discrete Markov chain model of the binary exponential increment half decrement (BEIHD) back-off algorithm. The method of BEIHD back-off algorithm is the binary exponential increment after a successful transmission. On the contrary, if the transmitted packet is successful, a new contention window size will be a half decrement. For simplicity, we denote

$$R_0^0 = [(1-(C/15))/7], R_0^1 = [1-(C/31)] \quad (20)$$

$$R_0^2 = [1-(C/63)], R_0^3 = [1-(C/127)] \quad (21)$$

$$R_0^4 = [1-(C/255)], R_0^5 = [1-(C/511)] \quad (22)$$

$$R_0^6 = [1-(C/1023)] \quad (23)$$

The state probabilities of BEIHD back-off algorithm are similarly derived to the previous back-off algorithms, and which are given by

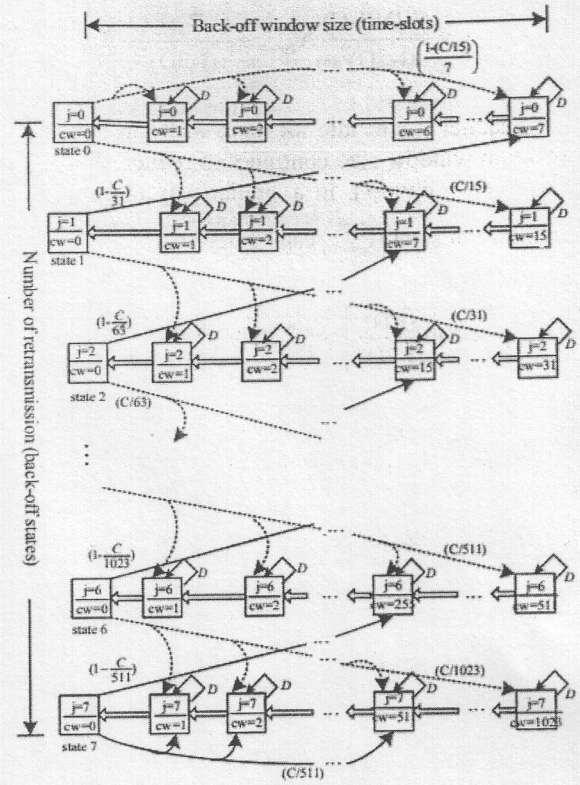

Figure 3 BEIHD back-off algorithm

$$A_{cw=0}^{j=0} = \frac{(1-C/15)}{7[R_0^0+C/15]} \sum_{Z=1}^7 H^Z A_{cw=0}^{j=0} + \frac{(1-C/31)}{(R_0^0+C/15)} H^7 A_{cw=0}^{j=1} \quad (24)$$

$$A_{cw=0}^{j=1} = \frac{C}{15(R_0^1+C/31)} \sum_{Z=1}^7 H^Z A_{cw=0}^{j=0} + \frac{C}{15[R_0^1+C/31]} H^7 \sum_{Z=1}^8 H^Z A_{cw=0}^{j=0} + \frac{1-(C/63)}{(R_0^1+C/31)} H^7 A_{cw=0}^{j=2} \quad (25)$$

$$A_{cw=0}^{j=2} = \frac{C}{31(R_0^2+C/63)} \sum_{Z=1}^{15} H^Z A_{cw=0}^{j=1} + \frac{C}{31[R_0^2+C/63]} H^{15} \sum_{Z=1}^{16} H^Z A_{cw=0}^{j=1} + \frac{1-(C/127)}{(R_0^2+C/63)} H^{15} A_{cw=0}^{j=3} \quad (26)$$



$$A_{cw=0}^{j=3} = \frac{C}{63(R_0^3+C/127)} \sum_{Z=1}^{31} H^Z A_{cw=0}^{j=2} + \frac{C}{63[R_0^3+C/127]} H^{31} \sum_{Z=1}^{32} \left[ \frac{(1-D)}{(1-2D)} \right]^Z A_{cw=0}^{j=2} + \frac{1-(C/255)}{(R_0^3+C/127)} H^{31} A_{cw=0}^{j=4} \quad (27)$$

$$A_{cw=0}^{j=4} = \frac{C}{127(R_0^4+C/255)} \sum_{Z=1}^{63} H^Z A_{cw=0}^{j=3} + \frac{C}{127[R_0^4+C/255]} H^{63} \sum_{Z=1}^{64} H^Z A_{cw=0}^{j=3} + \frac{1-(C/511)}{(R_0^4+C/255)} H^{63} A_{cw=0}^{j=5} \quad (28)$$

$$A_{cw=0}^{j=5} = \frac{C}{255(R_0^5+C/511)} \sum_{Z=1}^{127} H^Z A_{cw=0}^{j=4} + \frac{C}{255[R_0^5+C/511]} H^{127} \sum_{Z=1}^{128} H^Z A_{cw=0}^{j=4} + \frac{1-(C/1023)}{(R_0^5+C/511)} H^{127} A_{cw=0}^{j=6} \quad (29)$$

$$A_{cw=0}^{j=6} = \frac{C}{511(R_0^6+C/1023)} \sum_{Z=1}^{255} H^Z A_{cw=0}^{j=5} + \frac{C}{511[R_0^6+C/1023]} H^{255} \sum_{Z=1}^{256} H^Z A_{cw=0}^{j=5} + \frac{1-(C/511)}{(R_0^6+C/1023)} H^{255} A_{cw=0}^{j=7} \quad (30)$$

$$A_{cw=0}^{j=7} = \frac{C}{1023(R_0^6+C/511)} \sum_{Z=1}^{511} H^Z A_{cw=0}^{j=6} + \frac{C}{1023[R_0^6+C/511]} H^{511} \sum_{Z=1}^{512} H^Z A_{cw=0}^{j=6} + \frac{C}{511(R_0^5+C/511)} H^{511} A_{cw=0}^{j=7} \quad (31)$$

Finally, the RIBED back-off algorithm is modeled in a discrete Markov chain as shown in Figure 4. The difference among the DIDD, EIED, and BEIHD back-off techniques is that the transmission is unsuccessful and a new contention window size is randomly increased. On the contrary, if the transmission is successful, the new contention window size is reset to an initial back-off state. Similarly, the state probabilities of RIBED back-off algorithm can be derived as

$$A_{cw=0}^{j=0} = \left[ \frac{1-(C/15)}{C/8} \right] \sum_{Z=1}^{15} H^Z \left[ \frac{C/8}{H^{15}} \right] A_{cw=0}^{j=1} \quad (32)$$

$$A_{cw=0}^{j=1} = \left[ \frac{C/8}{1-(C/15)} \right] \sum_{Z=1}^{15} H^Z A_{cw=0}^{j=0} \quad (33)$$

$$A_{cw=0}^{j=2} = \left[ \frac{C/8}{1-(C/31)} \right] \sum_{Z=1}^{31} H^Z A_{cw=0}^{j=0} \quad (34)$$

$$A_{cw=0}^{j=3} = \left[ \frac{C/8}{1-(C/63)} \right] \sum_{Z=1}^{63} H^Z A_{cw=0}^{j=0} \quad (35)$$

$$A_{cw=0}^{j=4} = \left[ \frac{C/8}{1-(C/127)} \right] \sum_{Z=1}^{127} H^Z A_{cw=0}^{j=0} \quad (36)$$

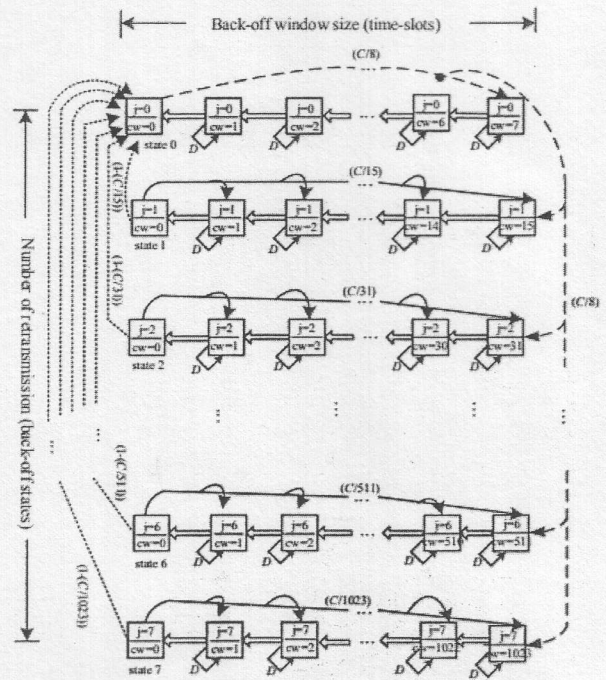

Figure 4 RIBED back-off algorithm

$$A_{cw=0}^{j=5} = \left[ \frac{C/8}{1-(C/255)} \right] \sum_{Z=1}^{127} H^Z A_{cw=0}^{j=0} \quad (37)$$

$$A_{cw=0}^{j=6} = \left[ \frac{C/8}{1-(C/511)} \right] \sum_{Z=1}^{511} H^Z A_{cw=0}^{j=0} \quad (38)$$

$$A_{cw=0}^{j=7} = \left[ \frac{C/8}{1-(C/1023)} \right] \sum_{Z=1}^{1023} H^Z A_{cw=0}^{j=0} \quad (39)$$

### 3. Proposed Back-Off Algorithms

A proposed back-off algorithm is developed from the previous works [1] explained in section 2. The proposed algorithm is improved by selecting a suitable contention window size between the half binary exponential increment after a failure transmission and the double decrement after a success packet. The proposed

algorithm is called half binary exponential increment double decrement (HBEIDD) back-off algorithm, and discrete time Markov chain model of the HBEIDD back-off is showed in Figure 5. Let us denote

$$V_0^0 = [(1 - (C/7))/7], V_0^1 = [1 - (C/15)] \quad (40)$$

$$V_0^2 = [1 - (C/31)], V_0^3 = [1 - (C/63)] \quad (41)$$

$$V_0^4 = [1 - (C/127)], V_0^5 = [1 - (C/255)] \quad (42)$$

$$V_0^6 = [1 - (C/511)], V_0^7 = [1 - (C/1023)] \quad (43)$$

$$V_0^8 = (C/1023) \quad (44)$$

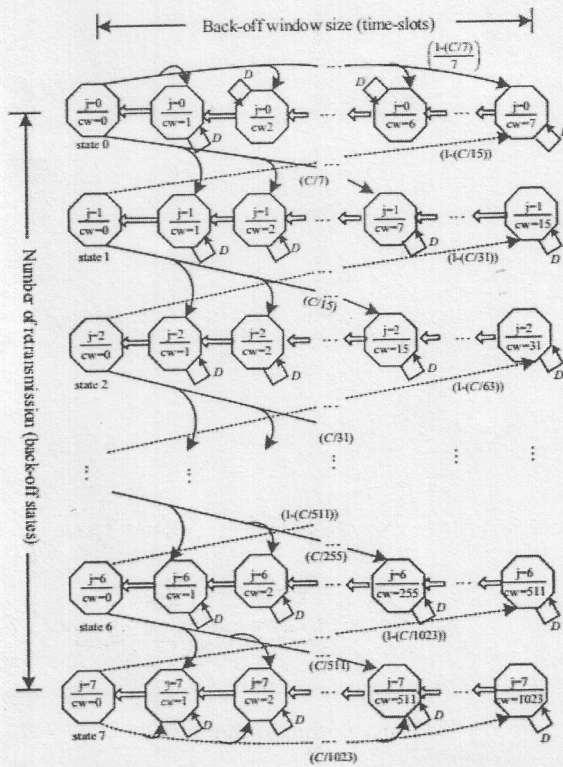

Figure 5 HBEIDD back-off algorithm

Similarly, we can show that the state probabilities of  $A_{cw=0}^{j=0}, A_{cw=0}^{j=1}, A_{cw=0}^{j=2}, A_{cw=0}^{j=3}, A_{cw=0}^{j=4}, A_{cw=0}^{j=5}, A_{cw=0}^{j=6}$  and  $A_{cw=0}^{j=7}$  are given by

$$A_{cw=0}^{j=0} = \frac{V_0^0}{(V_0^0 + C/7)} \sum_{Z=1}^7 H^Z A_{cw=0}^{j=0} + \frac{V_0^1}{[V_0^0 + C/7]} H^7 A_{cw=0}^{j=1} \quad (45)$$

$$A_{cw=0}^{j=1} = \frac{C}{7(V_0^1 + C/15)} \sum_{Z=1}^7 H^Z A_{cw=0}^{j=0} + \frac{V_0^2}{[V_0^1 + C/15]} H^{15} A_{cw=0}^{j=2} \quad (46)$$

$$A_{cw=0}^{j=2} = \frac{C}{15(V_0^2 + C/31)} \sum_{Z=1}^{15} H^Z A_{cw=0}^{j=1} + \frac{V_0^3}{[V_0^2 + C/31]} H^{31} A_{cw=0}^{j=3} \quad (47)$$

$$A_{cw=0}^{j=3} = \frac{C}{31(V_0^3 + C/63)} \sum_{Z=1}^{31} H^Z A_{cw=0}^{j=2} + \frac{V_0^4}{[V_0^3 + C/63]} H^{63} A_{cw=0}^{j=4} \quad (48)$$

$$A_{cw=0}^{j=4} = \frac{C}{63(V_0^4 + C/127)} \sum_{Z=1}^{63} H^Z A_{cw=0}^{j=3} + \frac{V_0^5}{[V_0^4 + C/127]} H^{127} A_{cw=0}^{j=5} \quad (49)$$

$$A_{cw=0}^{j=5} = \frac{C}{127(V_0^5 + C/255)} \sum_{Z=1}^{127} H^Z A_{cw=0}^{j=4} + \frac{V_0^6}{[V_0^5 + C/255]} H^{255} A_{cw=0}^{j=6} \quad (50)$$

$$A_{cw=0}^{j=6} = \frac{C}{255(V_0^6 + C/511)} \sum_{Z=1}^{255} H^Z A_{cw=0}^{j=5} + \frac{V_0^7}{[V_0^6 + C/511]} H^{511} A_{cw=0}^{j=7} \quad (51)$$

$$A_{cw=0}^{j=7} = \frac{C}{511(V_0^7 + V_0^8)} \sum_{Z=1}^{511} H^Z A_{cw=0}^{j=6} + \frac{V_0^8}{[V_0^7 + V_0^8]} H^{1023} A_{cw=0}^{j=7} \quad (52)$$

#### 4. Saturated Throughput Calculation

The transmission probability of competing node ( $\Lambda_{sat.}$ ) is the summation of state  $A_{cw=0}^{j=0}$  to  $A_{cw=0}^{j=7}$ , and the transmission probability is an important parameter to calculate the theoretical throughput. The transmission probability of contending nodes can be calculated from

$$\Lambda_{sat} = \frac{1}{\sum_{j=1}^7 A_{cw=0}^j} = \frac{1}{\begin{pmatrix} A_{cw=0}^0 + A_{cw=0}^1 + A_{cw=0}^2 + \\ A_{cw=0}^3 + A_{cw=0}^4 + A_{cw=0}^5 + \\ A_{cw=0}^6 + A_{cw=0}^7 \end{pmatrix}} \quad (53)$$

All contending nodes are operated in the infrastructure mode, and channel access control uses the CSMA/CA protocol with RTS CTS mode. The procedure of packet transmission is shown in Figure 6. In this research, we concern only the saturated throughput to compare the performance of all back-off algorithms. Similarly to [1], the maximum theoretical saturation throughput is given by

$$\text{Sat. Throughput} = \frac{\Theta_{suc} \Theta_{trans} \times (\text{MSDU} \times 8)}{\left[ (1 - \Theta_{trans}) T_{slot} + \Theta_{trans} \Theta_{suc} T_{success} + \Theta_{trans} \Theta_{collis} T_{collision} \right]} \quad (54)$$

$$\Theta_{trans} = 1 - (1 - \Lambda_{sat})^n \quad (55)$$

$$\Theta_{suc} = n \Lambda_{sat} (1 - \Lambda_{sat})^{n-1} / [1 - (1 - \Lambda_{sat})^n] \quad (56)$$

$$\Theta_{collis} = 1 - \Theta_{suc} \quad (57)$$

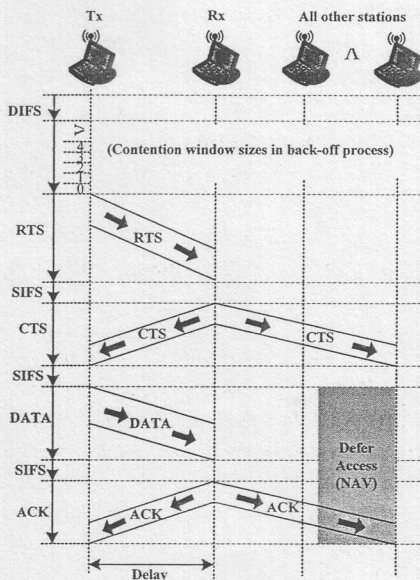

Figure 6 Transmission periods of CSMA/CA in RTS CTS mode

In Figure 6, transmission periods of success and collision packets are calculated from

$$T_{success} = \text{DIFS} + \text{RTS} + \text{CTS} + 3\text{SIFS} + 4\text{delay} + \text{Data} + \text{ACK} \quad (58)$$

$$T_{collision} = \text{RTS} + \text{DIFS} + \text{delay} \quad (59)$$

$$\text{Data} = [\text{MSDU} \times 8 \text{ bits}] / [\text{Speed (Mbps)}] \quad (60)$$

Parameter  $\Theta_{trans}$  means the transmission probability,  $\Theta_{suc}$  means the success probability, and  $\Theta_{collis}$  means the collision probability.  $T_{success}$  is the time period of successful transmission, and  $T_{collision}$  is the collision period. In addition, parameter  $n$  means the number of contending nodes in service area. Time periods of CSMA/CA protocol with RTS CTS mode based on IEEE802.11a at 54-Mbps use to calculate all throughputs of back-off algorithms. Physical layer parameters of IEEE802.11a are listed: a time-slot ( $T_{slot} = 9 \mu s$ ), short inter frame space (SIFS =  $16 \mu s$ ), DCF inter frame space (DIFS =  $34 \mu s$ ), medium service data unit (MSDU = 1024 bytes), request to send frame (RTS =  $24 \mu s$ ), clear to send frame (CTS =  $24 \mu s$ ), delay ( $9 \mu s$ ), control frame speed (1 Mbps), data speed (54 Mbps), and acknowledgment frame (ACK =  $304 \mu s$ ). The saturated throughput of all back-off algorithms are calculated by using the proposed Algorithm 1

Algorithm 1: saturated throughput calculation

Begin

Step: 1 to set parameters  $D := 0.05$ ,  $n := 1, 2, 3, \dots, 40$

Step: 2 to calculate the transmission probability of DIDD back-off algorithm used equations (53), (4)-(11).

Step: 3 to calculate the transmission probability of EIED back-off algorithm used equations (53), (12) to (19).

Step: 4 to calculate the transmission probability of BEIHD back-off algorithm used equations (53), (24) to (31).

Step: 5 to calculate the transmission probability of BEIHD back-off algorithm used equations (53), (32) to (39).

Step: 6 to calculate the transmission probability of HBEIDD back-off algorithm used equations (53), (45) to (52).

Step: 7 to calculate the periods:  $T_{success}$ ,  $T_{collision}$ , and Data used equations (58), (59) to (60).

Step: 8 to calculate saturated throughput used equations (54) to (57)

End

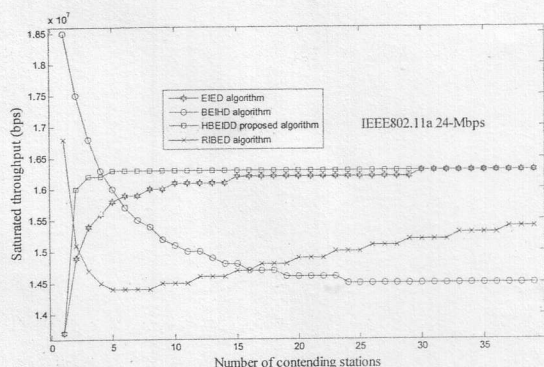

**Figure 7** Saturated throughput of considered back-off algorithms

### 5. Numerical Results and Discussion

For this research, numerical results are analyzed from different techniques of contention window size adjustment. The performance of all back-off algorithms focuses on the saturation throughput efficiency as shown in Figure 7. All back-off techniques are calculated in the same length of contention window size and back-off states. In this case, the correlation between saturation throughputs and number of contending nodes are compared. The results highlight that the saturated throughput of BEIHD back-off algorithm is higher than the other back-off algorithms on a few contending nodes. The results show that when the contending stations are more than 4 nodes, the saturated throughput of HBEIDD back-off algorithm is better than the performance of all considered back-off algorithms. Until the contending nodes have more than 30 stations, the maximum saturation throughput seems to be the both HBEIDD and EIED back-off algorithms. On average, the numerical result of the HBEIDD back-off algorithm is a suitable contention window size adjustment scheme at high traffic load condition.

### 6. Conclusions

The purpose of this research determines a new contention window size adjustment scheme for improving the saturated throughput of wireless local area network. A proposed technique is the half binary exponential increment double decrease (HBEIDD) back-off algorithm. The performance of HBEIDD back-off algorithm and the considered back-off algorithms are compared by applying the discrete time Markov chain model in fixed back-off state and contention window size. Our numerical results show that the saturation throughput of HBEIDD back-off algorithm outperforms the existing back-off algorithms (DIDD, EIED, BEIHD and RIBED) at high traffic load condition. Further research needs to investigate the relation between throughput and packet delay of all back-off schemes in non-saturated channel based on IEEE 802.11n/ac.

### Acknowledgment

This work was financially supported by a research grant GB\_58\_13 from the Research and Development Institute, Nakhon Pathom Rajabhat University. The author would like to thank the anonymous reviewer for their helpful comments.

### References

- [1] Bianchi G. Performance Analysis of the IEEE 802.11 Distributed Coordination Function. **IEEE Journal on Selected Areas in Communications**. 2000; **18**: 535-547.
- [2] Tinnirello I, Bianchi G. Refinements on IEEE 802.11 distributed coordination function modeling approaches. **IEEE Transactions on Vehicular Technology**. 2010; **59**(3): 1055-1067.
- [3] Kwak BJ, Song NO. Performance Analysis of Exponential Backoff. **IEEE/ACM Transactions on Networking**. 2005; **13**: 343-355.
- [4] Chatzimisios P, Vitsas V, Boucouvalas AC, Tsoulfa M. Achieving performance enhancement in IEEE 802.11 WLANs by using the DIDD back-off mechanism. **International Journal of Communication Systems**. 2016; **20**: 23-41.
- [5] Chatzimisios P. **Performance modelling and enhancement of wireless communication protocols**. [Dissertation]. United Kingdom: Bournemouth University; 2004.
- [6] Song NO, Kwak B, Song J, Miller L. Analysis of EIED backoff algorithm for the IEEE 802.11 DCF. **Proceedings of IEEE Vehicular Technology Conference**. 2005; **13**: 2182-2186.
- [7] Jeonghoon M. **Performance Modeling of Communication Networks with Markov Chains**. Seoul Korea: Morgan & Claypool Publishers; 2010.
- [8] Sartthong J. **Back-off algorithms optimization for wireless local area networks [dissertation]**. King Mongkut's Institute of Technology Ladkrabang; 2014.
- [9] Balador A, Movaghar A, Jabbehdari S. History based contention window control in IEEE 802.11 MAC protocol in error prone channel. **Journal of Computer Science**. 2010; **6**(2): 205-209.
- [10] Rajagopalan N, Mala C. History based probabilistic backoff algorithm. **American Journal of Engineering and Applied Sciences**. 2012; **5**(3): 230-236.
- [11] Sumathi N, Sumathi CP. Backoff schemes for mobile adhoc networks- A survey. **Journal of Wireless Networking and Communications**. 2013; **3**(1): 1-5.
- [12] Anderton CW, Young M. Is our model for contention resolution wrong?. **9th ACM Symposium on Parallelism in Algorithms and Architectures**. 2017; **5**(1): 15-27.