

DiFonzo, D.F. "Satellites and Aerospace"
The Electrical Engineering Handbook
Ed. Richard C. Dorf
Boca Raton: CRC Press LLC, 2000

Satellites and Aerospace

74.1	Introduction
74.2	Satellite Applications
74.3	Satellite Functions
74.4	Satellite Orbits and Pointing Angles
74.5	Communications Link
74.6	System Noise Temperature and G/T
74.7	Digital Links
74.8	Interference
74.9	Some Particular Orbits
74.10	Access and Modulation
74.11	Frequency Allocations
74.12	Satellite Subsystems
74.13	Trends

Daniel F. DiFonzo
*Planar Communications
Corporation*

74.1 Introduction

The impact of satellites on world communications since commercial operations began in the mid-1960s is such that we now take for granted many services that were not available a few decades ago: worldwide TV, reliable communications with ships and aircraft, wide area data networks, communications to remote areas, direct TV broadcast to homes, position determination, and earth observation (weather and mapping). New and proposed satellite services include global personal communications to hand-held portable telephones, and broadband voice, video, and data to and from small user terminals at customer premises around the world.

Satellites function as line-of-sight microwave relays in orbits high above the earth which can see large areas of the earth's surface. Because of this unique feature, satellites are particularly well suited to communications over wide coverage areas such as for broadcasting, mobile communications, and point-to-multipoint communications. Satellite systems can also provide cost-effective access for many locations where the high investment cost of terrestrial facilities might not be warranted.

74.2 Satellite Applications

Figure 74.1 depicts several kinds of satellite links and orbits. The geostationary earth orbit (GEO) is in the equatorial plane at an altitude of 35,786 km with a period of one sidereal day (23h 56m 4.09s). This orbit is sometimes called the Clarke orbit in honor of Arthur C. Clarke who first described its usefulness for communications in 1945. GEO satellites appear to be almost stationary from the ground (subject to small perturbations) and the earth antennas pointing to these satellites may need only limited or no tracking capability.

An orbit for which the highest altitude (apogee) is greater than GEO is sometimes referred to as high earth orbit (HEO). Low earth orbits (LEO) typically range from a few hundred km to about 2000 km. Medium earth orbits (MEO) are at intermediate altitudes. Circular MEO orbits, also called Intermediate Circular Orbits (ICO)

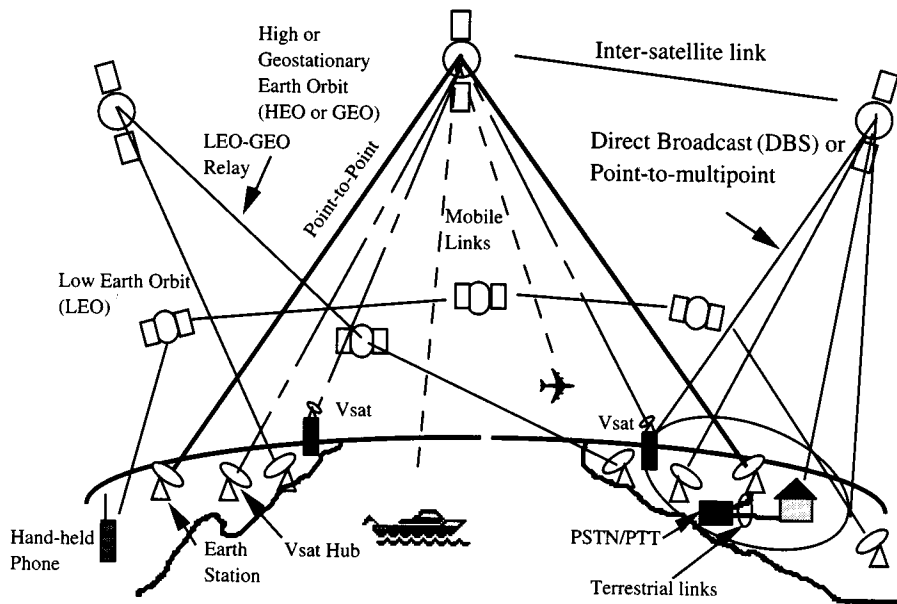

FIGURE 74.1 Several types of satellite links. Illustrated are point-to-point, point-to-multipoint, VSAT, direct broadcast, mobile, personal communications, and intersatellite links.

have been proposed at an altitude of about 10,400 km for global personal communications at frequencies designated for Mobile Satellite Services (MSS) [Johannsen, 1995].

LEO systems for voice communications are called *Big LEOs*. Constellations of so-called *Little LEOs* operating below 1 GHz and having only limited capacity have been proposed for low data rate non-voice services, such as paging and store and forward data for remote location and monitoring, for example, for freight containers and remote vehicles and personnel [Kiesling, 1996].

Initially, satellites were used primarily for point-to-point traffic in the GEO fixed satellite service (FSS), e.g., for telephony across the oceans and for point-to-multipoint TV distribution to cable *head end* stations. Large earth station antennas with high-gain narrow beams and high uplink powers were needed to compensate for limited satellite power. This type of system, exemplified by the early global network of the International Telecommunications Satellite Organization (INTELSAT) used Standard-A earth antennas with 30-m diameters. Since then, many other satellite organizations have been formed around the world to provide international, regional, and domestic services.

As satellites have grown in power and sophistication, the average size of the earth terminals has been reduced. High gain satellite antennas and relatively high power satellite transmitters have led to *very small aperture* earth terminals (VSAT) with diameters of less than 2 m, modest powers of less than 10 W [Gagliardi, 1991] and even smaller *ultra-small aperture terminals* (USAT) diameters typically less than 1 m. As depicted in Fig. 74.1, VSAT terminals may be placed atop urban office buildings, permitting private networks of hundreds or thousands of terminals, which bypass terrestrial lines. VSATs are usually incorporated into *star* networks where the small terminals communicate through the satellite with a larger *Hub* terminal. The hub retransmits through the satellite to another small terminal. Such links require two *hops* with attendant time delays. With high gain satellite antennas and relatively narrow-band digital signals, direct single-hop *mesh* interconnections of VSATs may be used.

74.3 Satellite Functions

The traditional function of a satellite is that of a bent pipe quasilinear repeater in space. As shown in Fig. 74.2, *uplink* signals from earth terminals directed at the satellite are received by the satellite's antennas, amplified, translated to a different *downlink* frequency band, channelized into *transponder channels*, further amplified to

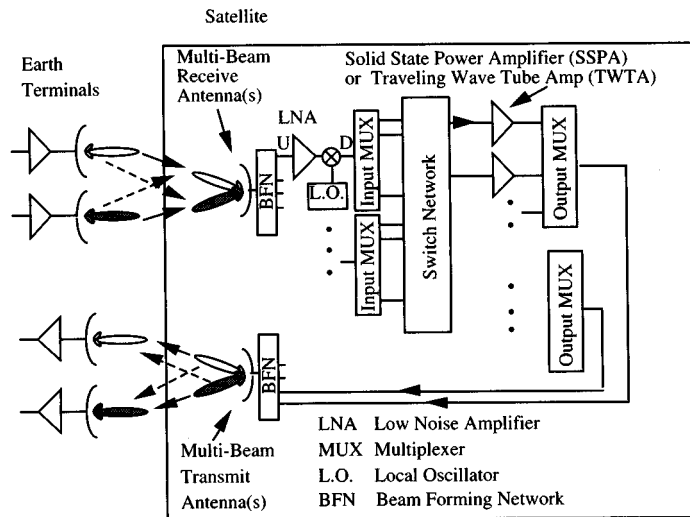

FIGURE 74.2 A satellite repeater receives uplink signals (U), translates them to a downlink frequency band (D), channelizes, amplifies to high power, and retransmits to earth. Multiple beams allow reuse of the available band. Interference (dashed lines) can limit performance. Downconversion may also occur after the input multiplexers. Several intermediate frequencies and downconversions may be used.

relatively high power, and retransmitted toward the earth. Transponder channels are generally rather broad (e.g., bandwidths from 24 MHz to more than 100 MHz) and each may contain many individual or user channels.

The functional diagram in Fig. 74.2 is appropriate to a satellite using frequency-division duplex (FDD), which refers to the fact that the satellites use separate frequency bands for the uplink and downlink and where both links operate simultaneously. This diagram also illustrates a particular *multiple access* technique, known as frequency-division multiple access (FDMA), which has been prevalent in mature satellite systems.

Multiple access, to be discussed later, allows many different user signals to utilize the satellite's resources of power and bandwidth without interfering with each other. Multiple access systems segregate users by frequency division (FDMA) where each user is assigned a specific frequency channel, space-division multiple access (SDMA) by *frequency reuse*, that is by reusing the same frequencies on multiple spatially isolated beams, time-division multiple access (TDMA) where each user signal occupies an entire allocated frequency band but for only part of the time, polarization-division (PD) where frequencies may be reused on spatially overlapping but orthogonally polarized beams, and code-division multiple access (CDMA) where different users occupy the same frequency band but use spread spectrum signals that contain orthogonal signaling codes [Sklar, 1988; Richharia, 1995].

Frequency modulation (FM) has been the most widely used modulation. However, advances in digital voice and video compression have led to the widespread use of digital modulation methods such as quadrature phase shift keying (QPSK) and quadrature amplitude modulation (QAM) [Sklar, 1988].

Newer satellite architectures incorporate digital modulations and on-board demodulation of the uplink signals to baseband bits, subsequent switching and assignment of the baseband signals to an appropriate downlink antenna beam, and re-modulation of the clean baseband signals prior to downlink transmission. These *regenerative repeaters* or *onboard processors* permit flexible routing of the user signals and can improve the overall communications link by separating the uplink noise from that of the downlink. The baseband signals may be those of individual users or they may represent frequency-division multiplexed (FDM) or time-division multiplexed (TDM) signals from many users.

Examples include the NASA Advanced Communications Technology Satellite (ACTS) and the Iridium[®] system built by Motorola for Iridium LLC. The ACTS is an FDD satellite system operating in the Ka-bands with uplink frequencies from 29.1 to 30.0 GHz and downlink frequencies from 19.2 to 20.1 GHz. It is intended to demonstrate technologies for future broadband voice, video, and data services applicable to the emerging concepts of the Global Information Infrastructure (GII) and National Information Infrastructure (NII) [Gedney, 1996].

Proposed Ka-band satellite systems that would operate at the 20- and 30-GHz bands may incorporate inter-satellite links at Ka-band or even at 60 GHz. These systems are intended to provide broadband voice, video, and data services for the GII. Systems have been proposed for operation at GEO and LEO.

The Iridium satellites operate at LEO (altitude = 780 km) with time-division duplex (TDD), using the same 1.6-GHz L-band frequencies for transmission and reception but only receiving or transmitting for somewhat less than half the time each. Iridium uses 66 LEO satellites for personal communications systems (PCS) to enable communications directly to and from small handheld portable telephones at any time and anywhere in the world. Other PCS satellite systems will operate at 1.6 GHz for the uplink and 2.5 GHz for the downlink (e.g., FCC filings for Globalstar and Odyssey).

High-power *direct broadcast satellites* (DBS) or *direct-to-home* (DTH) satellites are operating at Ku-band. In the U.S., satellites operating in the broadcast satellite service (BSS) with downlink frequencies of 12.2 to 12.7 GHz, deliver TV directly to home receivers having parabolic dish antennas as small as 46 cm (18 in.) in diameter. DBS with digital modulation and compressed video is providing more than 150 National Television Systems Committee (NTSC) TV channels from a single orbital location having an allocation of 32 transponder channels, each with 24-MHz bandwidth. DBS is seen as an attractive medium for delivery of high-definition TV (HDTV) to a large number of homes. Other systems using analog FM are operational in Europe and Japan. In the U.S., DTH is also provided by satellites in the FSS frequency bands of 11.7 to 12.2 GHz. These are constrained by regulation to operate at lower downlink power and, therefore, require receiving dishes of about 1-m diameter.

Digital radio broadcast (DRB) from high power GEO satellites has been proposed for direct broadcast of digitally compressed near-CD quality audio to mobile and fixed users in the 2310-2360 MHz bands. [Briskman, 1996].

Mobile satellite services (MSS) operating at L-band around 1.6 GHz have revolutionized communications with ships and aircraft, which would normally be out of reliable communications range of terrestrial radio signals. The International Maritime Satellite Organization (INMARSAT) operates the dominant system of this type.

Links between LEO satellites (or the NASA Shuttle), and GEO satellites are used for data relay, for example, via the NASA tracking and data relay satellite system (TDRSS). Some systems will use intersatellite links (ISL) to improve the interconnectivity of a wide-area network. ISL systems would typically operate at frequencies such as 23 GHz, 60 GHz, or even use optical links.

74.4 Satellite Orbits and Pointing Angles

Reliable communication to and from a satellite requires a knowledge of its position and velocity relative to a location on the earth. Details of the relevant astrodynamics formulas for satellite orbits are given in Griffin and French [1991], Morgan and Gordon [1989], and Chobotov [1991]. Launch vehicles needed to deliver the satellites to their intended orbits are described in Isakowitz [1991].

A satellite, having mass m , in orbit around the earth, having mass M_e , traverses an elliptical path such that the centrifugal force due to its acceleration is balanced by the earth's gravitational attraction, leading to the equation of motion for two bodies:

$$\frac{d^2\mathbf{r}}{dt^2} + \frac{\mu}{r^3} \mathbf{r} = 0 \quad (74.1)$$

where r is the radius vector joining the earth's center and the satellite and $\mu = G(m + M_e) \approx GM_e = 398,600.5 \text{ km}^3/\text{s}^2$ is the product of the gravitational constant and the mass of the earth. Because $m \ll M_e$, the center of rotation of the two bodies may be taken as the earth's center, which is at one of the focal points of the orbit ellipse.

Figure 74.3 depicts the orbital elements for a geocentric right-handed coordinate system where the x axis points to the first point of Aries, that is, the fixed position against the stars where the sun's apparent path around the earth crosses the earth's equatorial plane while traveling from the southern toward the northern

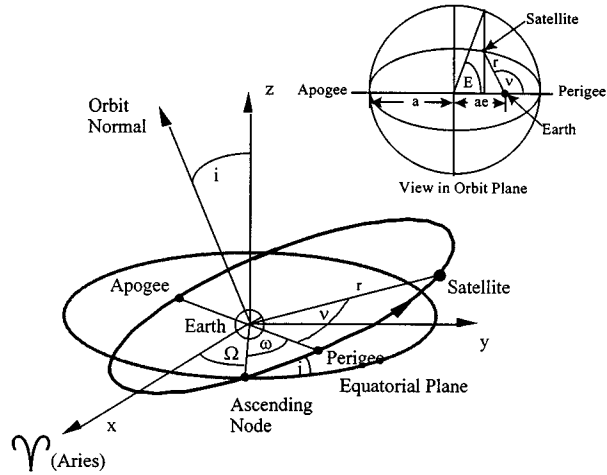

FIGURE 74.3 Orbital elements.

hemisphere at the vernal equinox. The z axis points to the north and the y axis is in the equatorial plane and points to the winter solstice. The elements shown are longitude or right ascension of the ascending node Ω measured in the equatorial plane, the orbit's inclination angle i relative to the equatorial plane; the ellipse semimajor axis length a , the ellipse eccentricity e , the argument (angle) of perigee ω , measured in the orbit plane from the ascending node to the satellite's closest approach to the earth; and the true anomaly (angle) in the orbit plane from the perigee to the satellite v .

The mean anomaly M is the angle from perigee that would be traversed by a satellite moving at its mean angular velocity n . Given an initial value M_o , usually taken as 0 for a particular epoch (time) at perigee, the mean anomaly at time t is $M = M_o + n(t - t_o)$, where $n = \sqrt{\mu/a^3}$. The eccentric anomaly E may then be found from Kepler's transcendental equation $M = E - e \sin E$ which must be solved numerically by, for example, guessing an initial value for E and using a root finding method. For small eccentricities, the series approximation $E \approx M + e \sin M + (e^2/2)\sin 2M + (e^3/8)(3\sin 3M - \sin M)$ yields good accuracy [Morgan and Gordon, 1989, p. 806]. Other useful quantities include the orbit radius, r , the period, P , of the orbit, [i.e., for $n(t - t_o) = 2\pi$], the velocity, V , and the radial velocity, V_r :

$$r = a(1 - e \cos E) \quad (74.2)$$

$$P = 2\pi\sqrt{a^3/\mu} \quad (74.3)$$

$$V^2 = \mu\left(\frac{2}{r} - \frac{1}{a}\right) \quad (74.4)$$

$$V_r = \frac{e(\mu a)^{1/2} \sin E}{a(1 - e \cos E)} \quad (74.5)$$

Figure 74.4 depicts quantities useful for communications links in the plane formed by the satellite, a point on the earth's surface and the earth's center. Shown to approximate scale for comparison are satellites at altitudes representing LEO, MEO, and GEO orbits.

For a satellite at altitude h , and for the earth's radius at the equator $r_e = 6378.14$ km, the slant range r_s , elevation angle to the satellite from the local horizon e_l , and the satellite's nadir angle θ , are related by simple

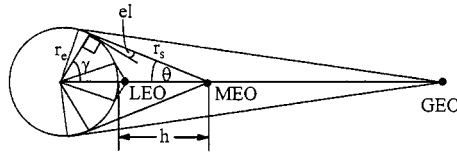

FIGURE 74.4 Geometry for a satellite in the plane defined by the satellite, the center of the earth, and a point on the earth's surface. The elevation angle, el , is the angle from the local horizon to the satellite. Shown to approximate scale are satellites at LEO, MEO (or ICO), and GEO.

trigonometry formulas. Note that $\theta + el + \gamma = 90^\circ$, where γ is the earth's central angle and the ground range from the subsatellite point is γr_e . Then,

$$k = \frac{r_e + h}{r_e} = \frac{\cos(el)}{\sin \theta} \quad (74.6)$$

$$\tan(el) = \frac{(\cos \gamma - 1/k)}{\sin \gamma} \quad (74.7)$$

$$r_s = r_e \sqrt{1 + k^2 - 2k \cos \gamma} \quad (74.8)$$

The earth station azimuth angle to the satellite measured clockwise from north in the horizon plane is given in terms of the satellite's declination d , the observer's latitude, ϕ , and the difference of the east longitudes of observer and satellite, $\Delta\lambda$. Then:

$$\tan A = \frac{\sin \Delta\lambda}{(\cos \phi \tan \delta - \sin \phi \cos \Delta\lambda)} \quad (74.9)$$

taking due account of the sign of the denominator to ascertain the quadrant.

The fraction of the earth's surface area covered by the satellite within a circle for a given elevation angle, el , and the corresponding earth central angle, γ , is

$$\frac{a_c}{a_e} = \frac{1 - \cos \gamma}{2} \quad (74.10)$$

74.5 Communications Link

Figure 74.5 illustrates the elements of the radio frequency (RF) link between a satellite and earth terminals. The overall link performance is determined by computing the link equation for the uplink and downlink separately and then combining the results along with interference and intermodulation effects.

For a radio link with only thermal noise, the received carrier-to-noise power ratio is

$$\left(\frac{c}{n}\right) = (p_t g_t) \left(\frac{1}{4\pi r_s^2}\right) \left(\frac{g_r}{T}\right) \left(\frac{1}{k}\right) \left(\frac{\lambda^2}{4\pi}\right) \left(\frac{1}{a}\right) (\rho) \left(\frac{1}{b}\right) \quad (74.11a)$$

The same quantities expressed in dB are

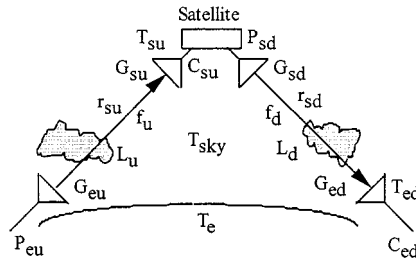

FIGURE 74.5 Quantities for a satellite RF link. P = transmit power (dBW). G = antenna gain (dBi). C = received carrier power (dBW). T = noise temperature (K). L = dissipative loss (dB). r_s = slant range (m). f = frequency (Hz). u = uplink. d = downlink. e = earth. s = satellite.

$$\begin{aligned} (C/N) = & EIRP - 10 \log(4\pi r_s^2) + (G_r - 10 \log T) \\ & + 228.6 - 10 \log(4\pi/\lambda^2) - A + \Gamma - B \end{aligned} \quad (74.11b)$$

where the subscripts in Eq. (74.11a) refer to transmit (t) and receive (r). Lower case terms are the actual quantities in watts, meters, etc. and the capitalized terms in Eq. (74.11b) correspond to the decibel (dB) versions of the parenthesized quantities in Eq. (74.11a). For example, $EIRP = P + G = 101 \log p + 101 \log g$ decibels relative to 1 W (dBW) and the expression (C/N) should be interpreted as $10 \log c - 10 \log n$. The uplink and downlink equations have identical form with the appropriate quantities substituted in Eq. (74.11). The relevant quantities are described below.

The ratio of received carrier power to noise power c/n , and its corresponding decibel value $(C/N) = 10 \log(c/n)$ dB is the primary measure of link quality. The product of transmit power p_t (W) and the transmit antenna gain g_t , or equivalently, P_t (dBW) + G_t [(dBi), that is, gain expressed in decibels relative to an isotropic antenna] is called the equivalent isotropically radiated power ($EIRP$) and its unit is dBW because the antenna gain is dimensionless. The antenna gain is that *in the direction of the link*, i.e., it is not necessarily the antenna's peak gain. The received thermal noise power is $n = kTB$ W where $k = 1.38 \times 10^{-23}$ J/K is Boltzmann's constant and $10 \log(k) = -228.6$ dBW/K/Hz. T is the system noise temperature in kelvins (K) and B is the bandwidth in dB Hz. Then, $G - 101 \log T$ dB/K is a figure of merit for the receiving system. It is usually written as G/T and read as "gee over tee". The antenna gain and the noise temperature must be defined at the same reference point, e.g., at the receiver's input port or at the antenna terminals.

The spreading factor $4\pi r_s^2$ is independent of frequency and depends *only* on the slant range distance r_s . The gain of an antenna with an effective aperture area of 1 m² is $10 \log(4\pi/\lambda^2)$, where the wavelength $\lambda = c/f$, f is the frequency in Hz, and $c = 2.9979 \times 10^8$ m/s is the velocity of light. The dB sum of the spreading factor and the gain of a 1-m² antenna is the frequency-dependent "path loss". "A" is the signal attenuation due to dissipative losses in the propagation medium. B is the bandwidth in dB Hz, i.e., $B = 10 \log(b)$ where b is the bandwidth in Hz.

The polarization mismatch factor between the incident wave and the receive antenna, is given by $\Gamma = 10 \log \rho$ where $0 \leq \rho \leq 1$. This factor may be obtained from the voltage axial ratio of the incident wave r_w , the voltage axial ratio of the receive antenna's polarization response r_a , and the difference in tilt angles of the wave and antenna polarization ellipses $\Delta\tau = \tau_w - \tau_a$, as follows

$$\rho = \frac{1}{2} + \frac{4r_w r_a + (r_w^2 - 1)(r_a^2 - 1) \cos(2\Delta\tau)}{2(r_w^2 + 1)(r_a^2 + 1)} \quad (74.12)$$

where the axial ratios are each signed quantities, having a positive sign for right-hand sense and a negative sign for left-hand sense. Therefore, if the wave and antenna are cross-polarized (have opposite senses), the sign of

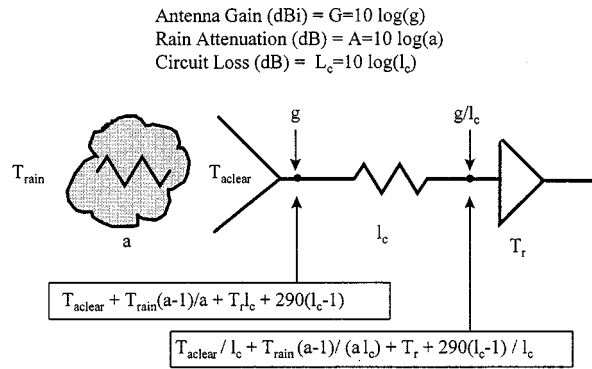

FIGURE 74.6 Tandem connection of antenna, loss elements such as waveguide, and receiver front end. The noise temperature depends on the reference plane but G/T is the same for both points shown.

$4r_w r_a$ is negative. The axial ratio in dB is given as $R = 10 \log |r|$. The polarization coupling is maximum when the wave and antenna are copolarized, have identical axial ratios, and their polarization ellipses are aligned ($\Delta\tau = 0$). It is minimum when the axial ratios are identical, the senses are opposite, and the tilt angles differ by 90° .

74.6 System Noise Temperature and G/T

The system noise temperature, T , incorporates contributions to the noise power radiated into the receiving antenna from the sky, ground, and galaxy, as well as the noise temperature due to circuit and propagation losses, and the noise figure of the receiver. The clear sky antenna temperature for a directive earth antenna depends on the elevation angle since the antenna's sidelobes will receive a small fraction of the thermal noise power radiated by the earth which has a noise temperature $T_{\text{earth}} \approx 290\text{K}$. At 11 GHz, the clear sky antenna noise temperature, T_{aclear} , ranges from 5 to 10 K at zenith ($el = 90^\circ$) to more than 50 K at $el = 5^\circ$ [Pratt and Bostian, 1986].

As shown in Fig. 74.6, the system noise temperature is developed from the standard formula for the equivalent temperature of tandem elements including the antenna in clear sky, propagation (rain) loss of $A = 10 \log(a)$ dB, circuit losses between the aperture and receiver of L_c dB, and receiver noise figure of F dB (corresponding to receiver noise temperature T_r K). The system noise temperature referred to the antenna aperture is approximated by the following equation where $T_{\text{rain}} \approx 280$ K is a reasonable approximation for the physical temperature of the rain [Pratt and Bostian, 1986, p. 342]:

$$T = T_{\text{aclear}} + T_{\text{rain}} \left(\frac{a-1}{a} \right) + T_r l_c + 290(l_c - 1) \quad (74.13)$$

The system noise temperature is defined at a specific reference point such as the antenna aperture or the receiver input. However, G/T is independent of the reference point when G correctly accounts for circuit losses. The satellite's noise temperature is generally higher than an earth terminal's under clear sky conditions because the satellite antenna sees a warm earth temperature of $\approx 150\text{--}300$ K, depending on the proportion of clouds, oceans, and land in the satellite antenna's beam, whereas a directive earth antenna generally sees cold sky and the sidelobes generally receive only a small fraction of noise power from the warm earth. Furthermore, a satellite receiving system generally has a higher noise temperature due to circuit losses in the beam forming networks, protection circuitry, and extra components for redundancy.

Figure 74.7 illustrates the link loss factors, maximum nadir angle, θ , earth central angle, γ , and earth-space time delay as a function of satellite altitude. The delay for a single hop between two earth locations includes the delays for the earth-space path, the space-earth path, and all circuit delays. The path losses are shown for several satellite frequencies in use. The variation in path loss and earth central angle is substantial. For example, L-band LEO personal communications systems to low-cost hand-held telephones with low gain (e.g., $G \approx$

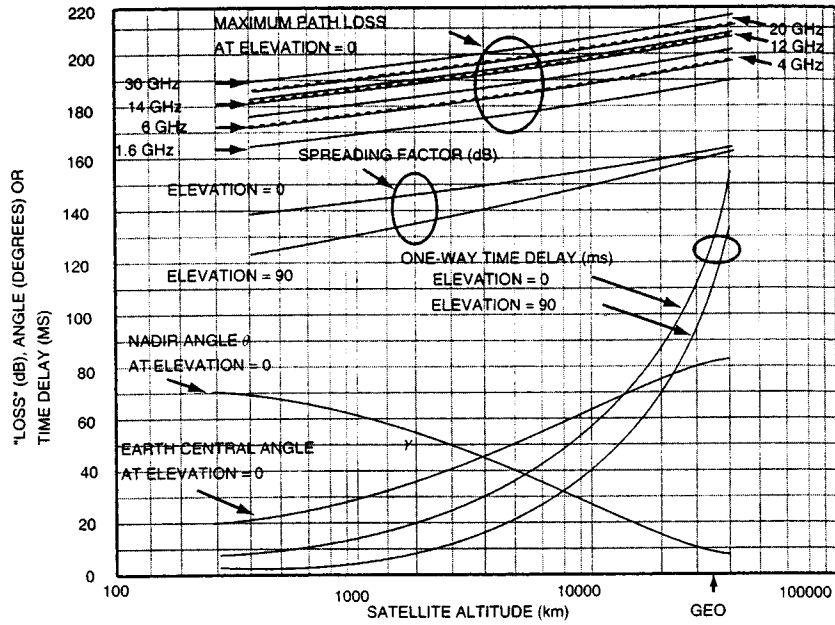

FIGURE 74.7 Satellite link losses, spreading factors, maximum nadir angle, θ_{max} , earth central angle, γ , and one-way time delay vs. satellite altitude, h km.

-2 to $+3$ dBi) need less link power than for MEO or GEO. On the other hand, more satellites are needed from LEO constellations to provide full earth coverage since each satellite sees a much smaller fraction of the earth compared with higher orbits.

The design for a constellation of satellites to serve communications needs, such as the number of satellites, their orbital parameters, the satellite G/T and $EIRP$, etc. are topics related to mission analysis and design and involve trades of many factors such as total communications capacity, link margins, space and earth segment costs, reliability, interconnectivity, availability and cost of launch vehicles, mission lifetime, and system operations [Wertz and Larson, 1991].

74.7 Digital Links

For digital modulation systems, the bit error rate (BER) is related to the dimensionless ratio (dB difference) of energy per bit, E_b dB J and the total noise power density $N_o = 10 \log(kT)$ dB J [Sklar, 1988]. For a system with only thermal noise N_o ,

$$\left(\frac{E_b}{N_o} \right) = \left(\frac{C}{N} \right) + B - R = \left(\frac{C}{N_o} \right) - R \text{ dB} \quad (74.14)$$

where $R = 10 \log$ (bit rate in bit/s), B is the bandwidth (dB Hz), and (C/N_o) is the *carrier-to-thermal noise density ratio*, that is, (C/N) normalized to unit bandwidth. Curves relating the communications performance measure of (BER) vs. (E_b/N_o) for different modulations may be found in [Sklar, 1988]. The link equation may then be expressed in terms of (E_b/N_o) and data rate, R , without explicit reference to the bandwidth:

$$\begin{aligned} \left(\frac{E_b}{N_o} \right) = & EIRP + \left(\frac{G}{T} \right) + 228.6 - 20 \log(4\pi r_s / \lambda) \\ & - A + \Gamma - R \text{ dB} \end{aligned} \quad (74.15)$$

where the appropriate quantities are substituted depending on whether the uplink or downlink is being considered.

74.8 Interference

A complete transponder link analysis must include the contributions of the uplink, downlink, and also the power sum of all interference signals due, for example, to intermodulation products generated in the output stages of the amplifiers, external interference from other systems, and intra-system interference from reusing the same frequency band on spatially isolated or dual-polarized antenna beams to increase communications capacity. For most applications the total interference power may be taken as the power sum of interfering signals as long as they are not correlated with each other or the desired carrier. The values for the interfering signals due to, for example, frequency reuse cross-polarization, multiple beam interferers, and interference power received from other systems, must be obtained by carefully constructing the link equation for each case, taking into account the antenna gains for each polarization and beam direction of concern.

For an interference power i W, and carrier power, c W the interference ratio, c/i must be combined with the uplink and downlink c/n values to yield the total c/n . Here, the ratios are written in lower case to indicate they are *numerical power ratios*.

$$\left(\frac{c}{n}\right)_{total} = \frac{1}{\left(\frac{c}{n}\right)_u^{-1} + \left(\frac{c}{n}\right)_d^{-1} + \left(\frac{c}{i}\right)_{other}^{-1}} \quad (74.16)$$

Equation (74.16) applies to a “bent pipe” satellite. If on-board signal regeneration is used for digital transmission, the uplink signal is demodulated and a *clean* set of baseband bits is remodulated. This has the effect of separating the accumulation of uplink and downlink noise contributions by causing the uplink noise to be effectively modulated onto the downlink carrier with the desired signal [Gagliardi, 1991]. In that case, only the uplink or the downlink term in the denominator of Eq. (74.16) would be used as appropriate. Remodulation is also useful for intersatellite links. In each case, a savings in power or antenna size may be obtained at the expense of circuit and processing complexity.

The degradation to a digital link from interference follows a form similar to that of Eq. (74.16) in terms of e_b/n_o where the lower case quantities refer to numerical ratios. For a link that is subject to a *given* additive white noise-like interference power expressed as a ratio of desired signal power to interference power, c/i , and assuming digital modulation with m bits per symbol,

$$\frac{e_b}{i_o} = \frac{1}{m} \frac{c}{i} \quad (74.17)$$

The ratio of energy per bit to total thermal noise plus interference power density is

$$\left(\frac{e_b}{n_o + i_o}\right) = \frac{1}{\left(\frac{e_b}{n_o}\right)^{-1} + \left(\frac{e_b}{i_o}\right)^{-1}} \quad (74.18)$$

For a system employing frequency reuse via dual polarizations, the polarization coupling factor Γ between a wave and antenna determines the interference power. The (C/I) due to polarization is the ratio of desired (copolarized) receive power and undesired (cross polarized) receive powers as measured at the same receive port. This *polarization isolation* may be found by application of Eq. (74.12) to co-polarized and cross-polarized cases.

74.9 Some Particular Orbits

A *geosynchronous* orbit has a period that is a multiple of the earth’s rotation period, but the orbit is not necessarily circular, and it may be inclined. A *geostationary* earth orbit (GEO) is a special case of a geosynchronous orbit

TABLE 74.1 Comparison of Orbit and Link Parameters for LEO, MEO, and GEO for the Particular Case of Circular Orbits (eccentricity, $e = 0$) and for Elevation Angle ($el = 10^\circ$)

Orbit	LEO	MEO/ICO	GEO
Example system	Iridium [®]	ICO-P	INTELSAT
Inclination, i (deg.)	86.4	± 45	0
Altitude, h (km)	780	10,400	35,786
Semi-major axis radius, a (km)	7159	16,778	42,164
Orbit period (minutes)	100.5	360.5	1436.1
$(r_e + h)/r_e$	1.1222	2.6305	6.6107
Earth central angle, γ (deg.)	18.658	58.015	71.433
Nadir angle, θ (deg.)	61.3	22	8.6
Nadir spread factor			
$10 \log(4\pi h^2)$ (dB m ²)	128.8	151.3	162.1
Slant range, r_s (km)	2325	14,450	40,586
One-way time delay (ms)	2.6	51.8	139.1
Maximum spread factor			
$10 \log(4\pi r_s^2)$ (dB m ²)	138.3	154.2	163.2
$20 \log(r_s/h)$ (dB)	9.5	2.9	1.1
Ground coverage area (km ²)	13.433×10^6	120.2×10^6	174.2×10^6
Fraction of earth area	0.026	0.235	0.34

Note: earth radius, r_e , (km) = 6378.14; earth surface area, a_e , (km²) = 511.2×10^6 ; elevation angle, el (degrees) = 10.

where $e = 0$, $i = 0$, $k = (r_e + h)/r_e = 6.61$, and $h = 35,786$ km. When $el = 0$ the maximum nadir angle $\theta = 8.7^\circ$, the maximum slant range is 41,680 km, and, from Eq. (74.7), $\gamma = 81.3^\circ$. Therefore, a GEO satellite cannot see the earth above 81.3° latitude [Gordon and Morgan, 1993].

Molniya and Tundra orbits have inclination $i = 63.4^\circ$. This highly inclined elliptical orbit (HIEO) causes the satellite's subsatellite ground trace to dwell at apogee at the same place each day. One such orbit whose subsatellite path traces a repetitive loop (LOOPUS) allows several satellites to be phased to offer quasi-stationary satellite service at high latitudes. For full earth coverage from a constellation of LEO satellites, circular polar constellations [Adams and Rider, 1987] and constellations of orbit planes with different inclinations, e.g., Walker Orbits [Walker, 1977] have received attention.

The oblateness of the earth causes the right ascension of the ascending node Ω (Fig. 74.3) to move with time in the equatorial plane in a direction opposite to the satellite's motion as seen from above the ascending node. This is called regression of the nodes. For inclination $i < 90^\circ$ (prograde orbit) the ascending node rotates westward. For $i > 90^\circ$ (retrograde orbit) the ascending node rotates eastward. For $i = 90^\circ$ the regression is zero. The orbit parameters may be chosen such that the nodal regression is $360^\circ/365.24 = 0.9856^\circ$ eastward per day. In that case, the orbit plane will maintain a constant angle with the sun. The local solar time for the line of nodes is constant, that is, the satellite crosses a given latitude at the same solar time and same solar lighting conditions each day. This *sun-synchronous* orbit has advantages for certain applications such as weather and surveillance satellites [Roddy, 1996 p. 60].

Table 74.1 compares the geometry, coverage, and some parameters relevant to the communications links for typical LEO, MEO (or ICO), and GEO systems. Reference should be made to Fig. 74.4 for the geometry and to the given equations for geometrical and link parameters.

74.10 Access and Modulation

Satellites act as central relay nodes, which are visible to a large number of users who must efficiently use the limited power and bandwidth resources. For detailed discussions of access issues see Gagliardi [1991], Pritchard et al. [1993], Miya [1985], Roddy [1996], and Feher [1983]. A brief summary of issues specific to satellite systems is now given.

Frequency-division multiple access (FDMA) has been the most prevalent access for satellite systems until recently. Individual users assigned a particular frequency band may communicate at any time. Satellite filters

sub-divide a broad frequency band into a number of *transponder channels*. For example, the 500 MHz uplink FSS band from 5.925 to 6.425 GHz may be divided into 12 transponder channels of 36 MHz bandwidth plus guard bands. This limits the interference among adjacent channels in the corresponding downlink band of 3.7 to 4.2 GHz.

FDMA implies that several individual carriers co-exist in the transmit amplifiers. In order to limit intermodulation products caused by non-linearities, the amplifiers must be operated in a *backed off* condition relative to their saturated output power. For example, to limit third-order intermodulation power for two carriers in a conventional traveling wave tube (TWT) amplifier to \hat{A} -20 dB relative to the carrier, its input power must be reduced (*input backoff*) by about 10 dB relative to the power that would drive it to saturation. The output power of the carriers is reduced by about 4 to 5 dB (*output backoff*). Amplifiers with fixed bias levels will consume power even if no carrier is present. Therefore, DC-to-RF efficiency degrades as the operating point is backed off. For amplifiers with many carriers, the intermodulation products have a noise-like spectrum and the noise power ratio is a good measure of multi-carrier performance.

When reusing the available frequency spectrum by multiple spatially isolated beams (SDMA), interference can result if the sidelobes of one beam receives or transmits substantial energy in the direction of the other beams. Two beams that point in the same direction may reuse frequencies provided that they are orthogonally polarized, for example, vertical and horizontal linear polarizations or right- and left-hand circular polarizations. Typical values of sidelobe or polarization isolation among beams reusing the same frequency bands are from 27 to 35 dB.

Time-division multiple access (TDMA) users share a common frequency band and are each assigned a unique time slot for their digital transmissions. At any instant the DC-RF efficiency is high because there is only one carrier in the transmit amplifier, which may be operated near saturation. A drawback is the system complexity required to synchronize widely dispersed users in order to avoid intersymbol interference caused by more than one signal appearing in a given time slot. Also, the total transmission rate in a TDMA satellite channel must be essentially the sum of the users' rates, including overhead bits such as for framing, synchronization and clock recovery, and source coding. Earth terminal hardware costs for TDMA have been higher than for FDMA. Nevertheless, TDMA systems have gained acceptance for some applications as their costs decreased.

Code-division multiple access (CDMA) modulates each carrier with a unique pseudo-random code, usually by means of either a direct sequence or frequency hopping spread spectrum modulation. CDMA users occupy the same frequency band at the same time. The aggregate signal in the satellite amplifier is noise-like and individual signals are extracted at the receiver by correlation processes. CDMA tolerates noise-like interference but does not tolerate large deviations from average loading conditions. One or more very strong carriers could violate the noise-like interference condition and generate strong intermodulation signals. Careful power control of each user's signal is usually required in CDMA systems.

User access is via assignments of a frequency, time slot, or code. Fixed assigned channels allow a user unlimited access. However, this may result in poor utilization efficiency for the satellite resources and may imply higher user costs (analogous to a leased terrestrial line). Other assignment schemes include *demand assigned multiple access* (DAMA) and *random access* (e.g., for the Aloha concept). DAMA systems require the user to first send a channel request over a common control channel. The network controller (at another earth station) seeks an empty channel and instructs the sending unit to tune to it either in frequency or time slot. A link is maintained for the call duration and then released to the system for other users to request. Random access is economical for lightly used burst traffic such as data. It relies on random time of arrival of data packets and protocols are in place for repeat requests in the event of collisions [Gagliardi 1991].

In practice, combinations of multiplexing and access techniques may be used. A broad band may be channelized or *frequency-division multiplexed* (FDM) and FDMA may be used in each sub-band (FDM/FDMA).

74.11 Frequency Allocations

Table 74.2 contains a partial list of frequency allocations for satellite communications. The World Administrative Radio Conference, WARC-92, allocated L-band frequencies for LEO personal communications services and for LEO small satellite data relay. The World Radiocommunication Conference, WRC-95, allocated S-Band frequencies for Mobile Satellite Services (MSS). Most of the other bands have been in force for years.

TABLE 74.2 Partial List of Satellite Frequency Allocations

Band	Uplink	Downlink	Satellite Service
VHF		0.137–0.138	Mobile
VHF	0.3120–0.315	0.387–0.390	Mobile
L-Band		1.492–1.525	Mobile
	1.610–1.6138		Mobile, radio astronomy
	1.613.8–1.6265	1.6138–1.6265	Mobile LEO
	1.6265–1.6605	1.525–1.545	Mobile
		1.575	Global positioning system
		1.227	GPS
S-Band	1.980–2.010	2.170–2.200	MSS (available Jan. 1, 2000)
	1.980–1.990	2.165–2.200	(proposed for U.S. in 2000)
	2.110–2.120	2.290–2.300	Deep-space research
		2.4835–2.500	Mobile
C-Band	5.85–7.075	3.4–4.2	Fixed (FSS)
	7.250–7.300	4.5–4.8	FSS
X-Band	7.9–8.4	7.25–7.75	FSS
Ku-Band	12.75–13.25	10.7–12.2	FSS
	14.0–14.8	12.2–12.7	Direct Broadcast (BSS) (U.S.)
Ka-Band		17.3–17.7	FSS (BSS in U.S.)
			22.55–23.55 Intersatellite
			24.45–24.75 Intersatellite
			25.25–27.5 Intersatellite
	27–31	17–21	FSS
Q	42.5–43.5, 47.2–50.2	37.5–40.5	FSS, MSS
	50.4–51.4		Fixed
		40.5–42.5	Broadcast Satellite
V	54.24–58.2–		Intersatellite
	59–64		Intersatellite

Note: Frequencies in GHz. Allocations are not always global and may differ from region to region in all or subsets of the allocated bands.

Sources: Final Acts of the World Administrative Radio Conference (WARC-92), Malaga-Torremolinos, 1992; 1995 World Radiocommunication Conference (WRC-95). Also, see Gagliardi [1991].

74.12 Satellite Subsystems

The major satellite subsystems are described in, for example, Griffin and French [1991]. They are propulsion, power, antenna, communications repeater, structures, thermal, **attitude** determination and control, telemetry, tracking, and command. Thermal control is described in [Gilmore, 1994].

The satellite *antennas* typically are offset-fed paraboloids. Typical sizes are constrained by launch vehicles and have ranged from less than 1 m to more than 5 m for some applications. The INTELSAT VI satellite used a 3.2 m antenna at 4 GHz. Ku-band satellites may use a diameter $D > 2$ m (i.e., $D > 80 \lambda$). Multiple feeds in the focal region each produce a narrow *component beam* whose beamwidth is $\approx 65\lambda/D$ and whose directions are established by the displacement of the feeds from the focal point. These beams are combined to produce a shaped beam with relatively high gain over a geographical region. Multiple beams are also used to reuse frequencies on the satellite. **Figure 74.2** suggests that a satellite may have several beams for frequency reuse. In that case, the carriers occupying the same frequencies must be isolated from each other by either polarization orthogonality or antenna sidelobe suppression. As long as the sidelobes of one beam do not radiate strongly in the direction of another, both may use the same frequency band to increase the satellite's capacity.

The *repeaters* include the following main elements (see Fig. 74.2): a low noise amplifier (LNA) amplifies the received signal and establishes the uplink noise. The G/T of the satellite receiver includes the effect of losses in the satellite antenna, the noise figure of the LNA, and the noise temperature of the earth seen from space (from 150 to 290 K depending on the percentage of the beam area over oceans and clouds). In a conventional repeater, the overall frequency band is down-converted by a local oscillator (LO) and mixer from the uplink band to the downlink band. It is channelized by an input multiplexer into a number (e.g., 12) of transponder channels.

These channelized signals each are amplified by a separate high-power amplifier. Typically, a traveling wave tube amplifier (TWTA) is used with powers from a few watts to >200 W for a DBS. Solid-state amplifiers can provide more than 15 W at C- and Ku-Bands.

The *attitude determination and control system* (ADCS) must maintain the proper angular orientation of the satellite in its orbit in order to keep the antennas pointed to the earth and the solar arrays aimed toward the sun (for example). The two prevalent stabilization methods are spin stabilization and body stabilization. In the former, the satellite body spins and the angular momentum maintains gyroscopic stiffness. The latter uses momentum wheels to keep the spacecraft body orientation fixed. Components of this subsystem include the momentum wheels, torquers (which interact with the earth's magnetic field), gyros, sun and earth sensors, and thrusters to maintain orientation.

The *telemetry tracking and command* (TT&C) subsystem receives data from the ground and enables functions on the satellite to be activated by appropriate codes transmitted from the ground. This system operates with low data rates and requires omni-directional antennas to maintain ground contact in the event the satellite loses its orientation.

The *power* subsystem comprises batteries and a solar array. The solar array must provide enough power to drive the communications electronics as well as the housekeeping functions and it must also have enough capacity to charge the batteries that power the satellite during eclipse, that is, when it is shadowed and receives no power from the sun [Richharia, 1995, p. 39]. Typical battery technology uses nickel-hydrogen cells, which can provide a power density of more than 50 W-h/kg. Silicon solar cells can yield more than 170 W/m² at a satellite's beginning of life (BOL). Gallium arsenide solar cells (GaAs) yield more than 210 W/m². However, they are more expensive than silicon cells.

The space environment including radiation, thermal, and debris issues are described in Wertz and Larson [1991], Griffin and French [1991], and Committee on Space Debris [1995]. The structure must support all the functional components and withstand the rigors of the launch environment. The thermal subsystem must control the radiation of heat to maintain a required operating temperature for critical electronics [Gilmore, 1994].

74.13 Trends

Satellites continue to exploit their unique wide view of the earth for such applications as broadcast, mobile, and personal communications, and will find new niches for end-to-end broadband communications between customer premises by using the Ka-bands at 20 and 30 GHz and, perhaps, even higher frequencies. Historically, satellite construction has resembled a craft industry with extensive custom design, long lead times, long test programs, and high cost. New trends, pioneered by the lean production and design-to-cost concepts for the Iridium and Globalstar programs are leading to systems having lower cost per unit of capacity and higher reliability. Technology advances that are being pursued include development of light-weight small satellites for economical provision of data and communications services at low cost, more sophisticated on-board processing to improve interconnectivity, microwave and optical inter-satellite links, and improved components such as batteries and antennas with dynamically reconfigurable beams such as may be implemented by digital beam forming techniques [Bjornstrom, 1993].

Defining Terms

Attitude: The angular orientation of a satellite in its orbit, characterized by roll (R), pitch (P), and yaw (Y).

The roll axis points in the direction of flight, the yaw axis points toward the earth's center, and the pitch axis is perpendicular to the orbit plane such that $R \times P \rightarrow Y$. For a GEO satellite, roll motion causes north-south beam pointing errors, pitch motion causes east-west pointing errors, and yaw causes a rotation about the subsatellite axis.

Backoff: Amplifiers are not linear devices when operated near saturation. To reduce intermodulation products for multiple carriers, the drive signal is reduced or backed off. Input backoff is the decibel difference between the input power required for saturation and that employed. Output backoff refers to the reduction in output power relative to saturation.

Beam and polarization isolation: Frequency reuse allocates the same bands to several independent satellite transponder channels. The only way these signals can be kept separate is to isolate the antenna response for one reuse channel in the direction or polarization of another. The beam isolation is the coupling factor for each interfering path and is always measured at the receiving site, that is, the satellite for the uplink and the earth terminal for the downlink.

Bus: The satellite bus is the ensemble of all the subsystems that support the antennas and payload electronics. It includes subsystems for electrical power, attitude control, thermal control, TT&C, and structures.

Frequency reuse: A way to increase the effective bandwidth of a satellite system when available spectrum is limited. Dual polarizations and multiple beams pointing to different earth regions may utilize the same frequencies as long as, for example, the gain of one beam or polarization in the directions of the other beams or polarization (and vice versa) is low enough. Isolations of 27 to 35 dB are typical for reuse systems.

Related Topics

69.1 Modulation and Demodulation • 73.2 Noise

References

- W. S. Adams and L. Rider, "Circular polar constellations providing continuous single or multiple coverage above a specified latitude," *J. Astronautical Sci.*, 35(2), 155-192, April-June 1987.
- G. Bjornstrom, "Digital payloads: enhanced performance through signal processing," *ESA Journal*, 17, 1-29, 1993.
- R. D. Briskman, *Satellite Radio Technology*, Washington, D.C.: 16th International Communications Satellite Systems Conference, American Institute of Aeronautics and Astronautics, Feb. 25-29, 1996, pp. 821-825.
- A. Chobotov, *Orbital Mechanics*, 2nd ed., Washington, D.C.: American Institute of Aeronautics and Astronautics, 1991.
- S. De Gaudenzi, F. Gianetti, and M. Luise, "Advances in satellite CDMA transmission for mobile and personal communications," *Proc. IEEE*, 84 (1), 18-39, 1996.
- Committee on Space Debris, National Research Council, *Orbital Debris*, Washington, D.C., National Academy Press, 1995.
- K. Feher, *Digital Communications: Satellite/Earth Station Engineering*, Englewood Cliffs, N.J.: Prentice-Hall, 1983.
- M. Gagliardi, *Satellite Communications*, New York: Van Nostrand Reinhold, 1991.
- R. Gedney, "Considerations for satellites providing NII/GII integrated services using ACTS results," Washington, D.C.: 16th International Communications Satellite Conference, paper AIAA-96-1027-CP, pp. 344-353, Feb. 25-29, 1996.
- D. G. Gilmore, Ed., *Satellite Thermal Control Handbook*, El Segundo, Calif.: The Aerospace Corporation Press, 1994.
- G. Gordon and W. Morgan, *Principles of Communications Satellites*, New York: John Wiley & Sons, 1993.
- M. D. Griffin and J. R. French, *Space Vehicle Design*, Washington, D.C.: American Institute of Aeronautics and Astronautics, 1991.
- J. Isakowitz, *International Reference Guide to Space Launch Systems*, 2nd ed., Washington, D.C.: American Institute of Aeronautics and Astronautics, 1991.
- K. G. Johannsen, "Mobile P-service satellite system comparison," *Iny. J. Satellite Comm.*, 13, 453-471, 1995.
- J. D. Kiesling, "Little LEOs", *an Important Satellite Service*, Washington, D.C.: American Institute of Aeronautics and Astronautics, 16th International Communications Satellite Systems Conference, Feb. 25-29, 1996, pp. 918-928.
- K. Miya, Ed., *Satellite Communications Technology*, Tokyo: KDD Engineering and Consulting, Inc., 1985.
- W. L. Morgan and G. D. Gordon, *Communications Satellite Handbook*, New York: John Wiley & Sons, 1989.
- T. Pratt and C. W. Bostian, *Satellite Communications*, New York: John Wiley & Sons, 1986.
- W. L. Pritchard, H. G. Suyderhoud, and R. A. Nelson, *Satellite Communications Systems Engineering*, 2nd ed., Englewood Cliffs, N.J.: Prentice-Hall, 1993.

- M. Richharia, *Satellite Systems, Design Principles*, New York: McGraw-Hill, 1995.
- Roddy, *Satellite Communications*, 2nd ed., Englewood Cliffs, N.J.: Prentice-Hall, 1996.
- A. Scott, *Understanding Microwaves*, New York: John Wiley & Sons, 1993.
- B. Sklar, *Digital Communications*, Englewood Cliffs, N.J.: Prentice-Hall, 1988.
- J. G. Walker, "Continuous whole-earth coverage by circular orbit satellite patterns," Technical Report 77044, Farnborough, Hants, U.K.: Royal Aircraft Establishment, 1977.
- J. R. Wertz, Ed., *Spacecraft Attitude Determination and Control*, Dordrecht, The Netherlands: D. Reidel Publishing Co., 1978.
- J. R. Wertz and W. J. Larsen, Eds., *Space Mission Analysis and Design*, Dordrecht, The Netherlands: Kluwer Academic Publishers, 1991.

Further Information

For a brief history of satellite communications see *Satellite Communications: The First Quarter Century of Service*, by D. Reese, Wiley, 1990. Propagation issues are summarized in *Propagation Effects Handbook for Satellite Systems Design*, NASA Reference Publication 1082(04), 1989. Descriptions of the proposed LEO personal communications systems are in the FCC filings for *Iridium* (Motorola), *Globalstar* (SS/Loral), *Odyssey* (TRW), *Ellipso* (Ellipsat), and *Aries* (Constellation Communications), 1991 and 1992. Also, see the FCC filing of Teledesic for a Ka-band LEO broadband system employing 840 satellites. For a discussion of the trends in satellite communications see *An Assessment of the Status and Trends in Satellite Communications 1986-2000*, NASA Technical Memorandum 88867, NASA Lewis Research Center, Cleveland Ohio, November, 1986. For a broad collection of satellite papers, see the AIAA conference proceedings Feb. 25-29,1995, Washington, D.C.

Many of the organizations mentioned can be accessed via the Internet. Several examples include (with the usual <http://> prefix): NASA (www.nasa.gov); International Telecommunications Union (ITU) (www.itu.ch); INTELSAT (www.intelsat.int:8080); Inmarsat (www.worldserver.pipex.com/inmarsat/index.htm); FCC (www.fcc.gov/); ICO Global Communications (www.i-co.co.uk); Motorola Satellite Communications (www.sat.mot.com); and Iridium LLC (www.iridium.com).